

Cargo Flexi System – lightweight aluminium stakes for every form of transport



Autonordic where safety is a requirement



Cargo Flexi

ALUMINIUM STAKES



Cargo Flexi XL

ALUMINIUM STAKES

- Available in whole lengths, or alternatively divisible stakes.
- Complies with authorities demands on mounting.
- Adapted to market standards.

Cargo Flexi System

- lightweight aluminium stakes for every form of transport

TECHNICAL INFORMATION

Cargo Flexi System		Max. load/stake
Cargo Flexi		5,000 Nm (0.5 tons)
Cargo Flexi XL		20,000 Nm (2.0 tons)

	Order No.	Designation	mm	Weight (kg)
A	800300	One part stake	2520	8.6
B	800303	Divisible stake	2520	10.1
C	800301	Top section	1325	4.8
D	800302	Bottom section	1315	5.3
E	800304	Socket	140	2.1
F	801120	One part stake XL	2420	22
G	801122	Socket XL	190	4.7

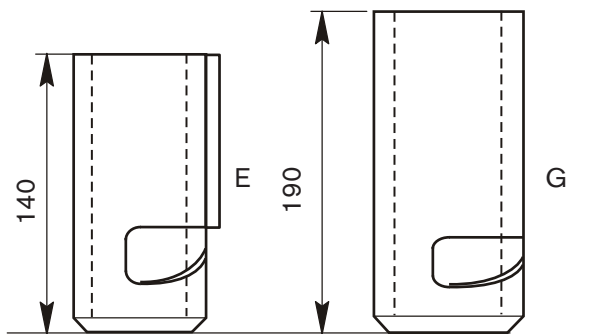
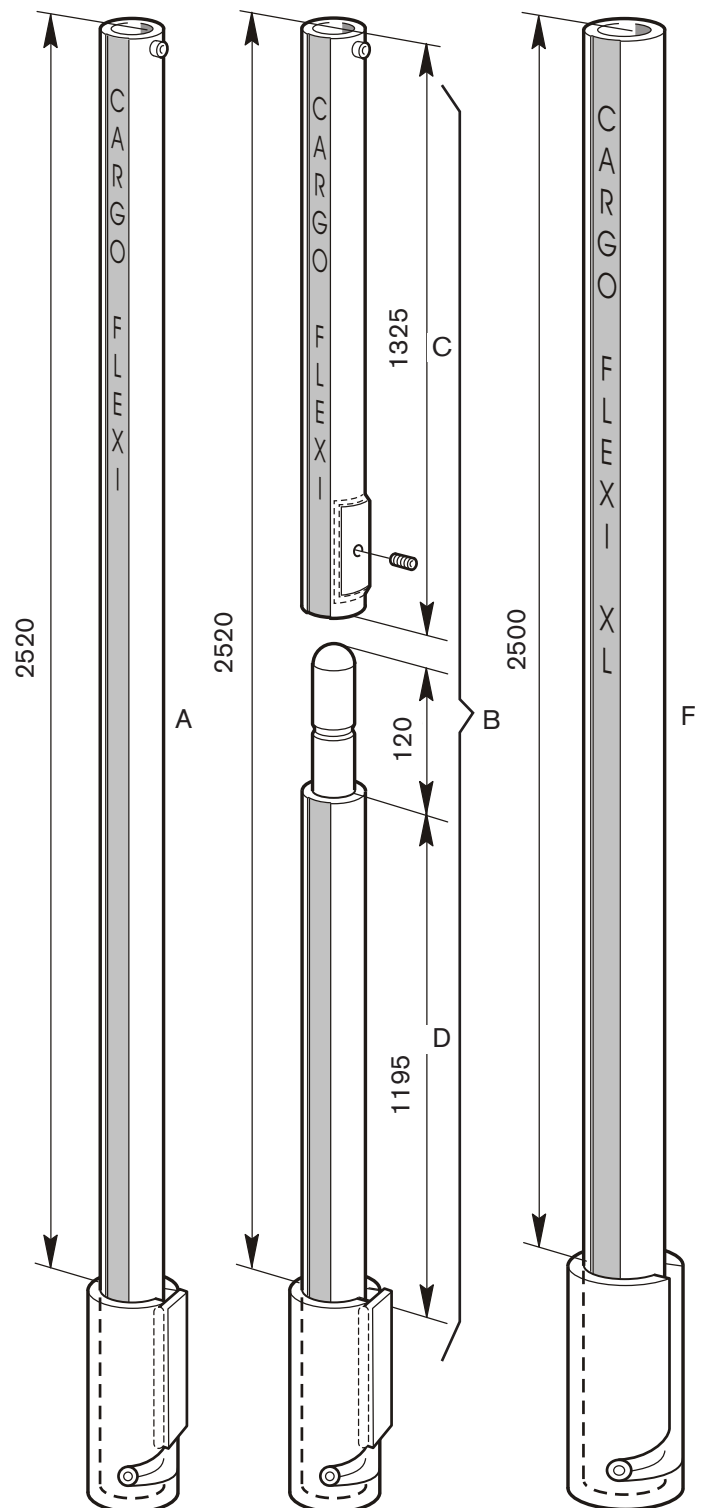

Cargo Flexi Hylsa

Cargo Flexi XL Hylsa

We reserve the right to make changes without prior notice.

AUTONORDIC[®]
LOAD SAFETY SYSTEM

ExTe Fabriks AB, SE-820 41 Färila Sweden.
Tel: +46 (0)651 175 00. Fax: +46 (0)651 175 03.
E-mail: info@exte.se www.autonordic.se