

# A-Series

## A10 Conical Lh 2.50-2.80

Doc.no AD00319

### Teknisk Data / Technical Details / Technische Daten

Max. Lastkapacitet per banke: 10 ton

Max. Load Capacity per bunk: 10ton

Max. Beladepazität pro Schemel beträgt: 10tonnen

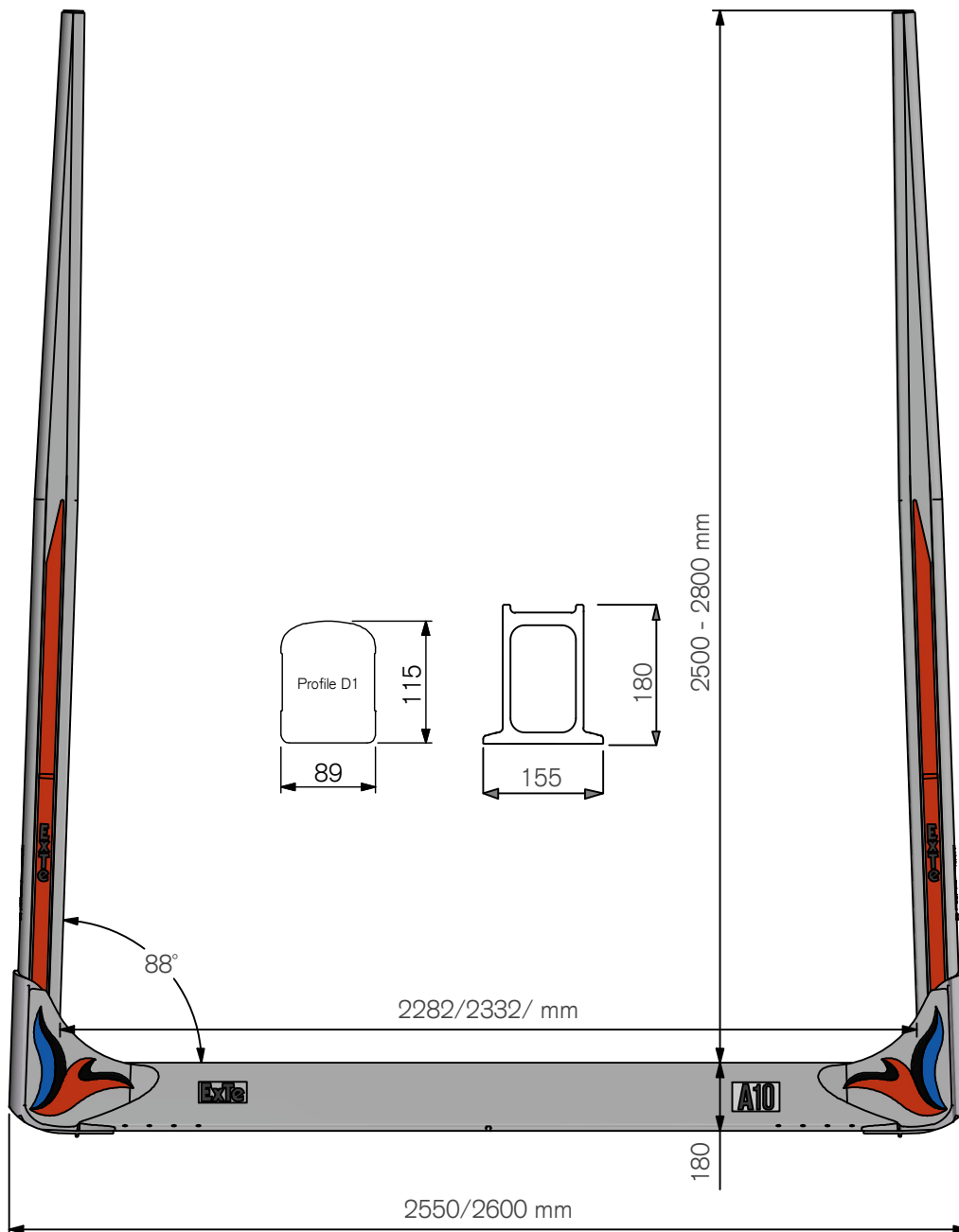

# ExTe

Securing cargo. We invented the concept.

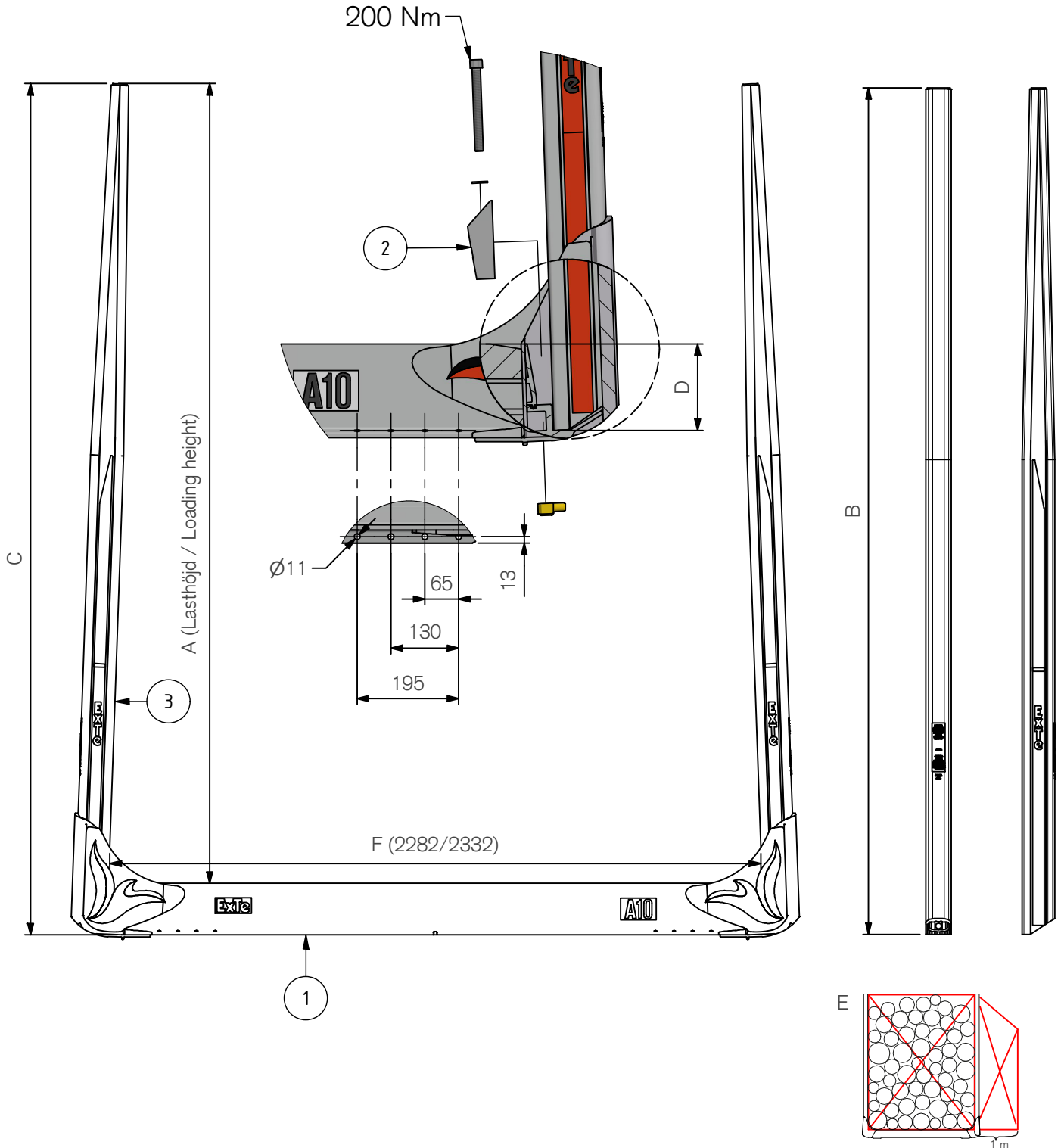

Pos.	Part.no	Pcs	Benämning	Description	Bezeichnung	Weight*	A mm	B mm	C mm	D mm	E1 m3	E2 m3
							Loading height	Length	Total Height	Depth	F 2282	F 2332
1	810375	1	Stomme A10 2,60	Bolster	Schemelkörper	58,1 kg						
1	810380	1	Stomme A10 2,55	Bolster	Schemelkörper	57,2 kg						
2	810196	2	Låselement D-Profil	Wedge kit	Keil	1,5 kg						
3	802818	2	Stake D1 T10 2660 Conical	Stake	Runge	28,9 kg	2500	2660	2680	160	5.71	5.83
3	802819	2	Stake D1 T10 2710 Conical	Stake	Runge	29,4 kg	2550	2710	2730	160	5.82	5.95
3	802820	2	Stake D1 T10 2760 Conical	Stake	Runge	29,9 kg	2600	2760	2780	160	5.93	6.06
3	802821	2	Stake D1 T10 2810 Conical	Stake	Runge	30,3 kg	2650	2810	2830	160	6.05	6.18
3	802822	2	Stake D1 T10 2860 Conical	Stake	Runge	30,8 kg	2700	2860	2880	160	6.16	6.3
3	802823	2	Stake D1 T10 2910 Conical	Stake	Runge	31,3 kg	2750	2910	2930	160	6.28	6.41
3	802824	2	Stake D1 T10 2960 Conical	Stake	Runge	32,0 kg	2800	2960	2980	160	6.39	6.53

ExTe förbehåller sig rätten att göra ändringar i specifikationer och annan information i detta dokument utan förhandsinformation.

ExTe reserves the right to make changes in specifications and other information contained in this document without prior notice.

ExTe behåller sig das Recht vor, Änderungen an Spezifikationen und anderen Informationen in diesem Dokument ohne vorherige Ankündigung vorzunehmen.



Securing cargo. We invented the concept.

\* Teoretiska

\* Theoretical

\* Theoretisch