

A-Series

A7 Conical-in Lh 2.65-3.05

Doc.no AD00067

Teknisk Data / Technical Details / Technische Daten

Max. Lastkapacitet per banke: 7 ton

Max. Load Capacity per bunk: 7 ton

Max. Beladekapazität pro Schemel beträgt: 7 tonnen

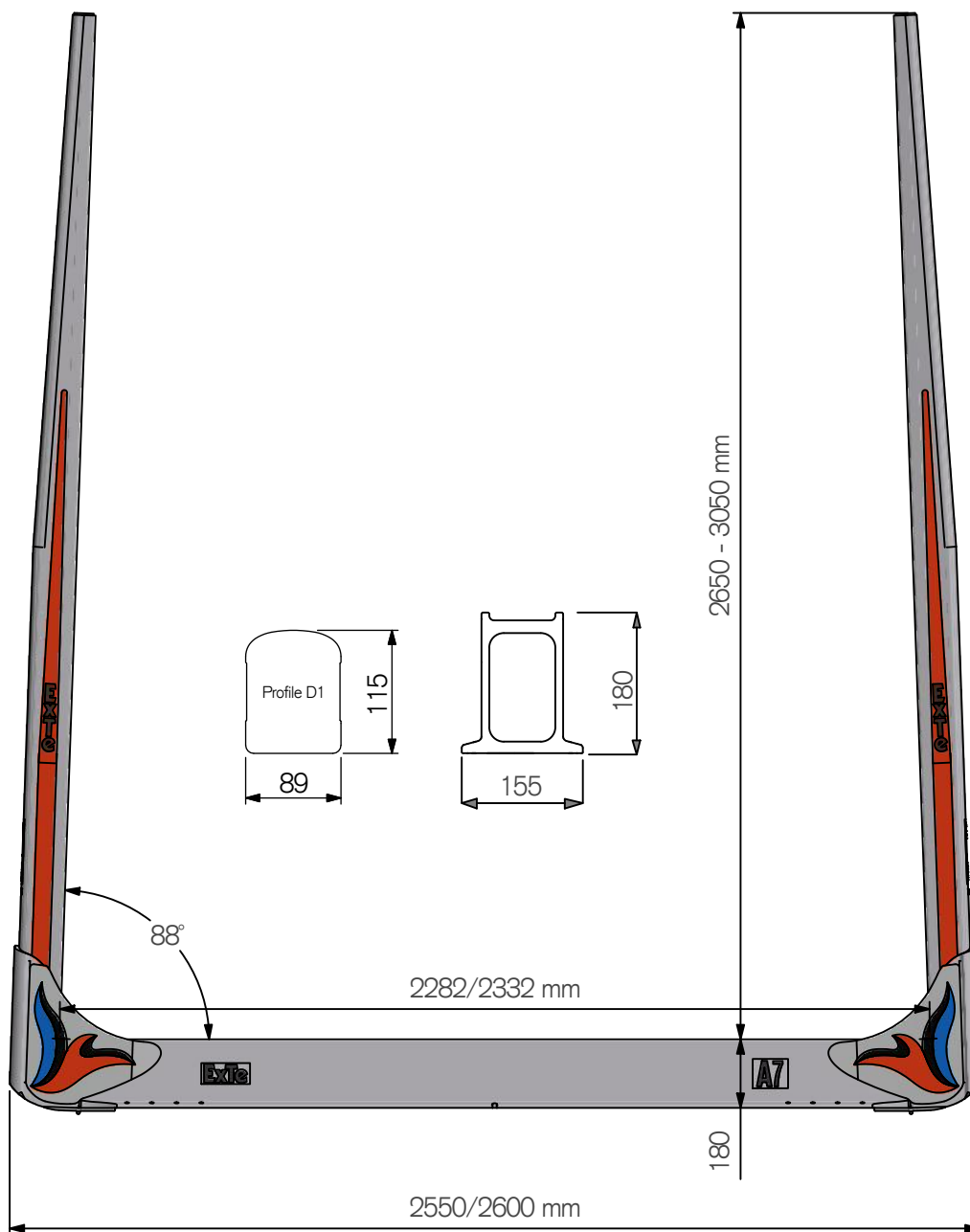

AD00067 B

ExtTe

Securing cargo. We invented the concept.

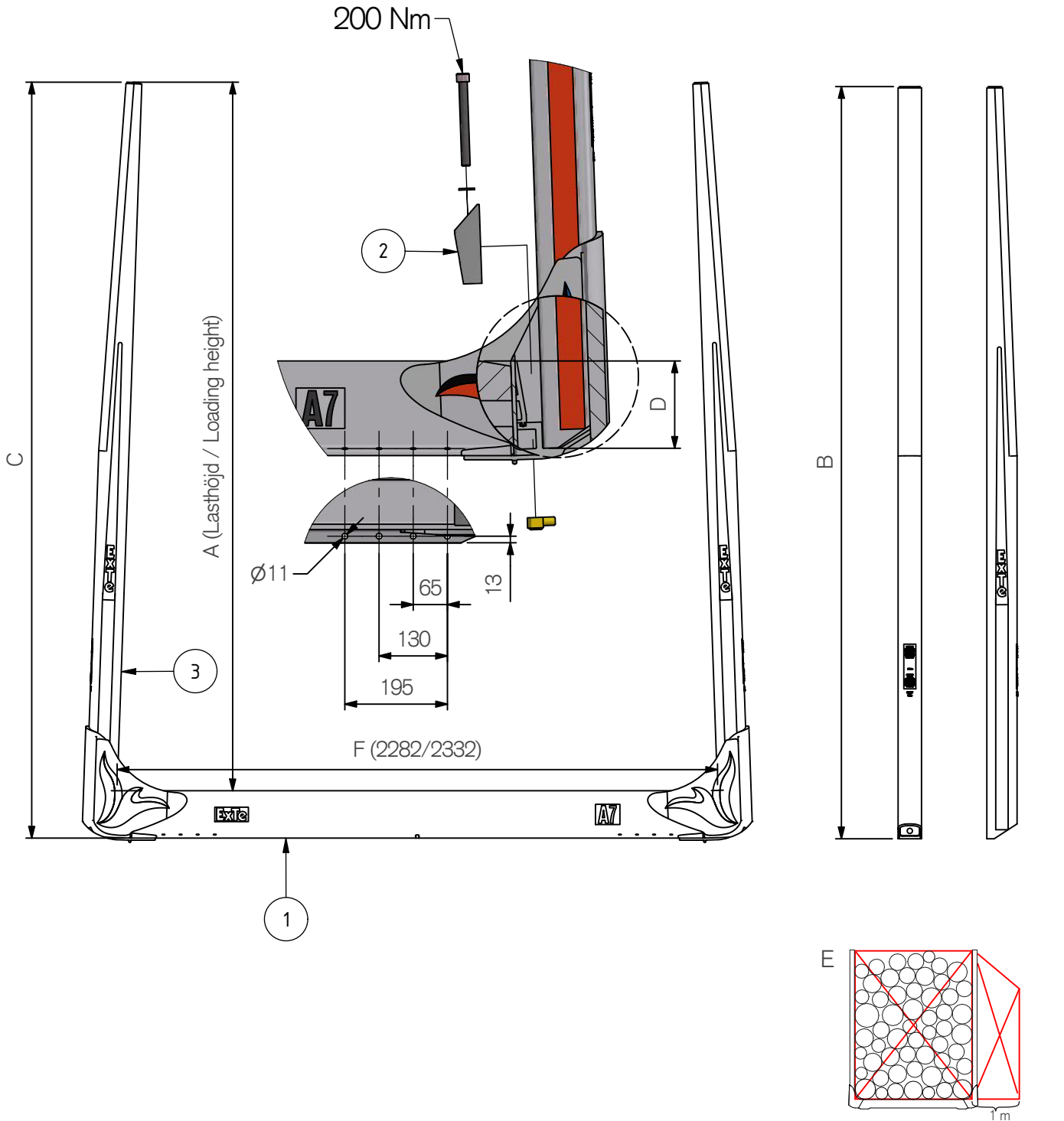

Pos.	Part.no	Pcs	Benämning	Description	Bezeichnung	Weight*	A mm	B mm	C mm	D mm	E1 m3	E2 m3
							Loading height	Length	Total Height	Depth	F 2282	F 2332
1	810350	1	Stomme A7 2,55	Bolster	Schemelkörper	53,2 kg						
1	810355	1	Stomme A7 2,60	Bolster	Schemelkörper	54,0 kg						
2	810196	2	Låselement D-Profil	Wedge kit	Keil	1,2 kg						
3	802618	2	Stake D1 T7 2810 Conical-in	Stake	Runge	20,7 kg	2650	2810	2830	160	6,05	6,18
3	802517	2	Stake D1 T7 2860 Conical-in	Stake	Runge	21,0 kg	2700	2860	2880	160	6,16	6,3
3	802619	2	Stake D1 T7 2910 Conical-in	Stake	Runge	21,4 kg	2750	2910	2930	160	6,28	6,41
3	802518	2	Stake D1 T7 2960 Conical-in	Stake	Runge	21,7 kg	2800	2960	2980	160	6,39	6,53
3	802620	2	Stake D1 T7 3010 Conical-in	Stake	Runge	22,0 kg	2850	3010	3030	160	6,5	6,65
3	802519	2	Stake D1 T7 3060 Conical-in	Stake	Runge	22,4 kg	2900	3060	3080	160	6,62	6,76
3	802621	2	Stake D1 T7 3110 Conical-in	Stake	Runge	22,7 kg	2950	3110	3130	160	6,73	6,88
3	802520	2	Stake D1 T7 3160 Conical-in	Stake	Runge	23,0 kg	3000	3160	3180	160	6,85	7
3	802739	2	Stake D1 T7 3210 Conical-in	Stake	Runge	23,4 kg	3050	3210	3230	160	6,96	7,11

ExTe förbehåller sig rätten att göra ändringar i specifikationer och annan information i detta dokument utan förhandsinformation.

ExTe reserves the right to make changes in specifications and other information contained in this document without prior notice.

ExTe behåller sig das Recht vor, Änderungen an Spezifikationen und anderen Informationen in diesem Dokument ohne vorherige Ankündigung vorzunehmen.

ExTe

Securing cargo. We invented the concept.

* Teoretiska

* Theoretical

* Theoretisch